

Box: PLOCK 2

BIKE	SUZUKI GSX-R 1000	PART NO.	SI-1004
YEAR	2009 - 2011	FIT KITS	Z039.10394
NOTES	Use standard fittings where not supplied Remove standard gasket if fitted.	DB-Killer	SCEXDBK28 - (Type EE)

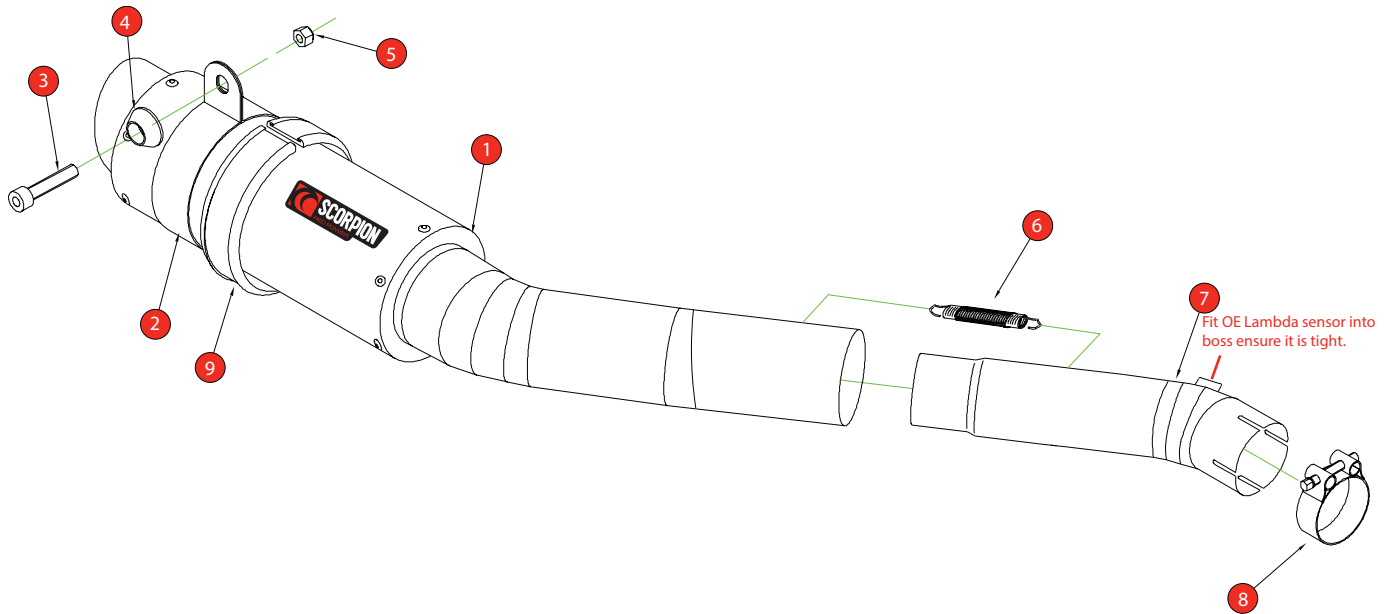

- | | |
|--|--|
| 1 225mm RP-1 GP Silencer with intergrated CP 580 | 8 59-63mm Band Clamp (Z016.10001) |
| 2 Titanium Silencer Strap (Z028.10013) | 9 Square edge rubber (275mm long) (Z029.10024) |
| 3 M8x40mm Cap Head Bolt (Z017.10076) | |
| 4 Bolt Finisher (Z026.20068) | |
| 5 M8 Nyloc Nut (Z017.10062) | |
| 6 Rubber Sleeved Spring (Z028.10030) | |
| 7 Connecting Pipe CP579 | |

E-MARK	BSAU 193a 1990/13
ISSUE NO.	04
DATE	22/10/2018
AUTHORISED	J.Harkin
CHECKED	

NOTE: ENSURE SCORPION SYSTEM IS CLEAR OF MOVING PARTS AND ALL ORIGINAL FUNCTIONS WORK CORRECTLY.



A) Remove original exhaust from bike, taking care to keep all original components in a safe place.

B) Refit Scorpion exhaust as per line diagram above.

C) When fitted take bike for a short ride to ensure all functions are correct.

D) When bike & exhaust are coll enough check all nuts and bolts are still secure.