

Box: PLOCK 1

BIKE	HONDA CBR 900 RR FIREBLADE 929	PART NO.	EHA - 69
YEAR	2000 - 2001	FIT KITS	OVAL Z039.11073 // ROUND Z039.10073
NOTES	Ensure billet is fitted with M8 x 16mm cap head bolts & spring washers prior to despatch	DB-Killer	SCEXDBK12 - (Type B)

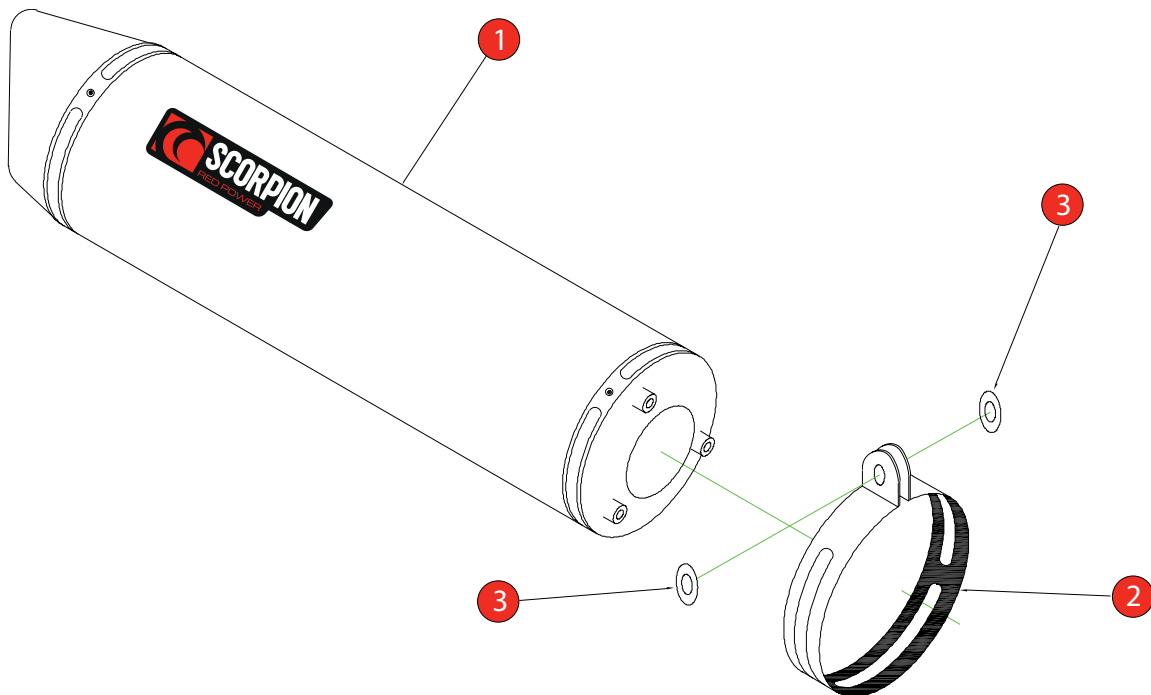

- 1 450mm Silencer (R-ZE40.22B) (O-ZE40.21B)
- 2 Composite Silencer Strap (R-Z038.10089) (O-Z038.10088)
- 3 2 x M8 x 25mm Washers (Z017.10825)

E-MARK ROUND	SCDB-RB E4 2103
E-MARK OVAL	SCDB-OB E4 2104
ISSUE NO.	07
DATE	16/10/2018
AUTHORISED	J.Harkin
CHECKED	

NOTE: ENSURE SCORPION SYSTEM IS CLEAR OF MOVING PARTS AND ALL ORIGINAL FUNCTIONS WORK CORRECTLY.

A) Remove original exhaust from bike, taking care to keep all original components in a safe place.

B) Refit Scorpion exhaust as per line diagram above.

C) When fitted take bike for a short ride to ensure all functions are correct.

D) When bike & exhaust are cool enough check all nuts and bolts are still secure.