

Box: PLOCK 2

BIKE	SUZUKI GSXR 1000	PART NO.	SI-1003
YEAR	2007 - 2008	FIT KITS	Z039.10386
NOTES	Removes Factory catalyst	DB-Killer	SCEXDBK21 - (Type U)

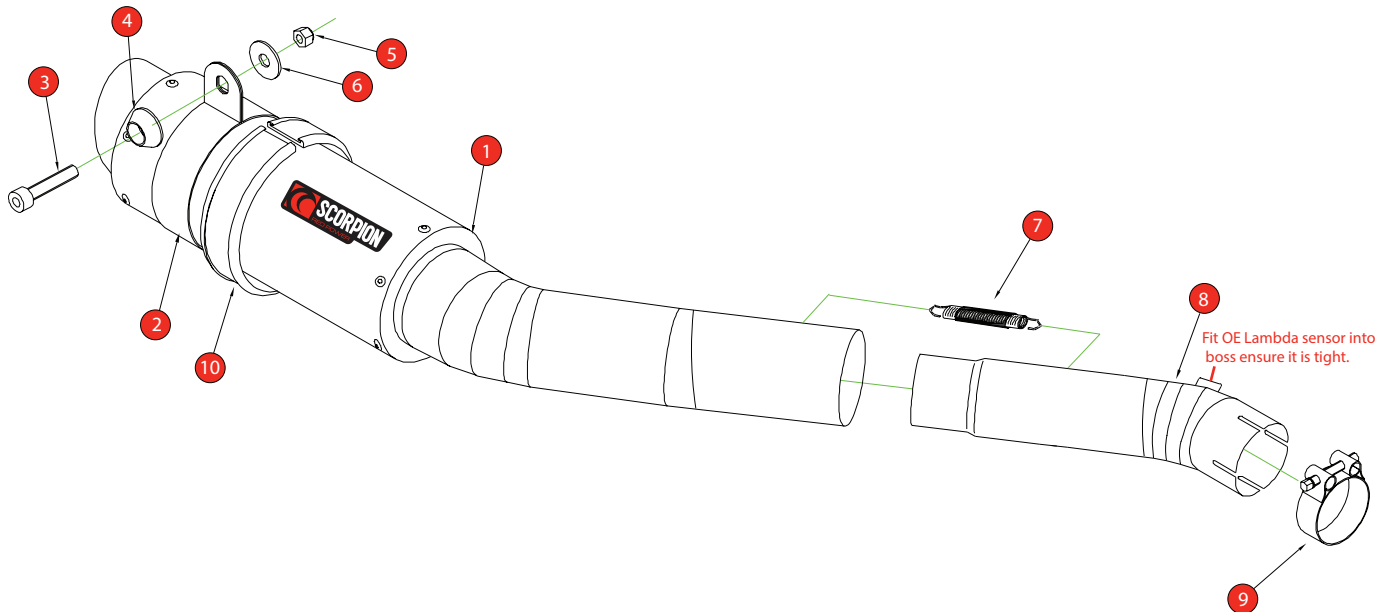

- |  |   |
|--|---|
| 1 225mm RP-1 GP Silencer with intergrated CP 577 | 8 Connecting pipe CP 576                        |
| 2 Titanium Silencer Strap (Z028.10013)           | 9 59-63mm Band Clamp (Z016.10001)               |
| 3 M8x40mm Cap Head Bolt (Z017.10076)             | 10 Square edge rubber (275mm long) (Z029.10024) |
| 4 Bolt Finisher (Z026.20068)                     |   |
| 5 M8 Nyloc Nut (Z017.10062)                      |   |
| 6 M8x17mm Washer (Z017.10831)                    |   |
| 7 Rubber Sleeved spring (Z028.10030)             |   |

E-MARK	BSAU 193a 1990/t3
ISSUE NO.	05
DATE	12/12/2019
AUTHORISED	D.Marshall
CHECKED	

**NOTE:** ENSURE SCORPION SYSTEM IS CLEAR OF MOVING PARTS AND ALL ORIGINAL FUNCTIONS WORK CORRECTLY.

A) Remove original exhaust from bike, taking care to keep all original components in a safe place.

B) Refit Scorpion exhaust as per line diagram above.

C) When fitted take bike for a short ride to ensure all functions are correct.

D) When bike & exhaust are cool enough check all nuts and bolts are still secure.

