

Box: PLOCK 1

BIKE	BMW F800GS	PART NO.	EBM -62
YEAR	2008 - 2017	FIT KITS	OVAL Z039.11256
NOTES	Use standard fittings where not supplied Remove standard gasket if fitted.	DB-Killer	SCEXDBK12 - (Type B)

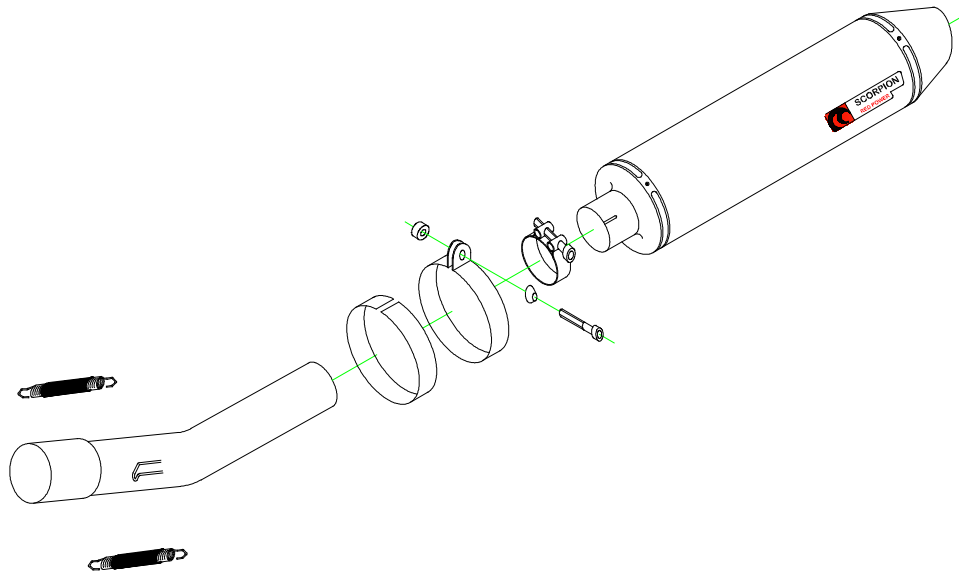

- | | |
|--|---|
| 1 400mm Oval Silencer ESC 51 | 8 2 off Rubber Sleeved Springs (Z028.10030) |
| 2 51-55mm Band Clamp (Z016.10002) | 9 M8 x 10mm Alloy |
| 3 M8 x 20mm Cap Head Bolt (Z017.10072) | |
| 4 Aluminium Bolt Finisher (Z026.20068) | |
| 5 Oval Silencer Strap (Z028.10230) | |
| 6 Silencer Strap Rubber (Z029.10022) | |
| 7 Connecting Pipe CP466 | |

E-MARK ROUND	N/A
E-MARK OVAL	BSAU 193a 1990/t3
ISSUE NO.	4
DATE	28/09/2018
AUTHORISED	J.Harkin
CHECKED	

NOTE: ENSURE SCORPION SYSTEM IS CLEAR OF MOVING PARTS AND ALL ORIGINAL FUNCTIONS WORK CORRECTLY.



A) Remove original exhaust from bike, taking care to keep all original components in a safe place.

B) Refit Scorpion exhaust as per line diagram above.

C) When fitted take bike for a short ride to ensure all functions are correct.

D) When bike & exhaust are cool enough check all nuts and bolts are still secure.