

Box: PLOCK 2

BIKE	SUZUKI GSX 1300 HAYABUSA	PART NO.	ESI - 66
YEAR	1999 - 2007	FIT KITS	OVAL Z039.11102 // ROUND Z039.10102
NOTES	Ensure billet is fitted with M8 x 16 cap heads & spring washers prior to despatch	DB-Killer	2 x SCEXDBK12 - (Type B)

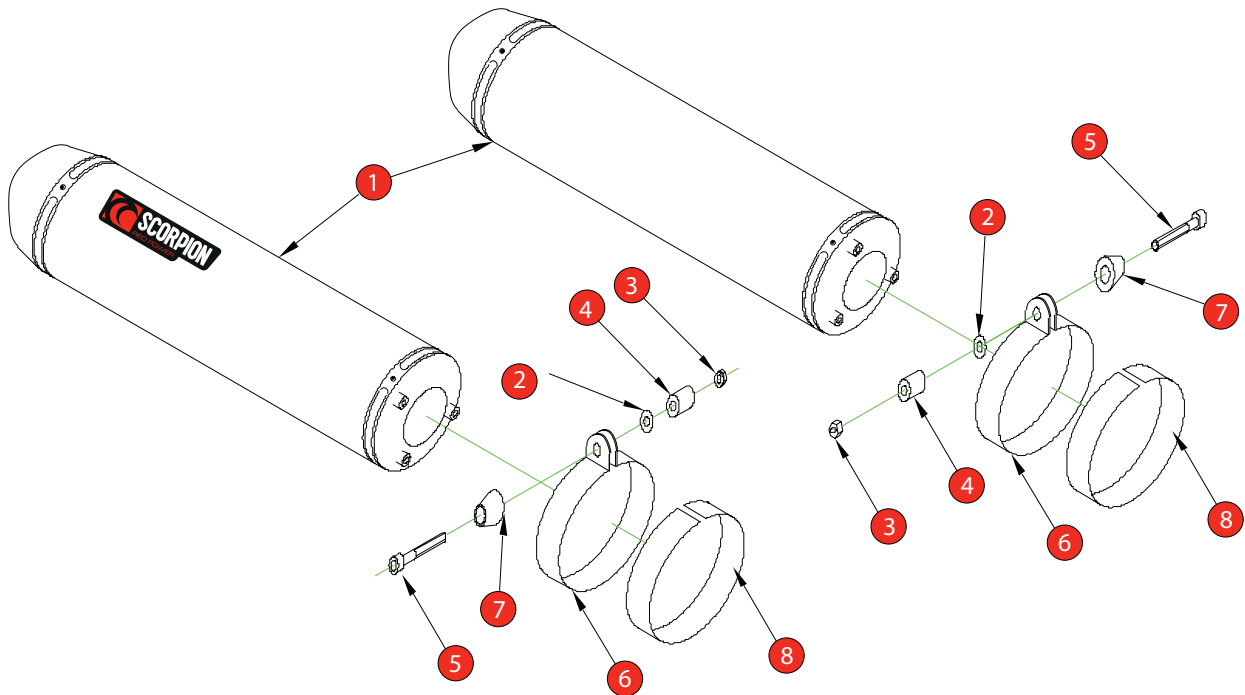

1	2 x 450mm Silencers (R-ZE40.03E + ZE40.03F) (O-ZE40.15E + ZE40.16F)	7	2 x Aluminium Bolt Finishers (Z026.20068)
2	2 x M8 x 25mm Washers (Z017.10825)	8	2 x Silencer Strap Rubbers (Z029.10022)
3	2 x M* Nyloc Nuts (Z017.10062)		
4	2 x 25mm Spacer (Z026.10007)		
5	2 x M8 x 70mm Cap Head Bolts (Z017.10082)		
6	2 x Silencer Straps (R-Z028.10228)(O-Z028.10231)		

E-MARK ROUND	BSAU 193a 1990/t3
E-MARK OVAL	BSAU 193a 1990/t3
ISSUE NO.	09
DATE	19/10/2018
AUTHORISED	J.Harkin
CHECKED	

NOTE: ENSURE SCORPION SYSTEM IS CLEAR OF MOVING PARTS AND ALL ORIGINAL FUNCTIONS WORK CORRECTLY.

A) Remove original exhaust from bike, taking care to keep all original components in a safe place.

B) Refit Scorpion exhaust as per line diagram above.

C) When fitted take bike for a short ride to ensure all functions are correct.

D) When bike & exhaust are cool enough check all nuts and bolts are still secure.